

OPERATING INSTRUCTIONS

Category II Pressure Accessory

Type D Reducing Valve



Notified Body No. 0038



Application

Suitable for liquid service.



Operation

The outlet pressure can be varied as required by compressing or relaxing the spring using the adjusting screw:

Clockwise turns compress the spring increasing outlet pressure.

Anti-clockwise turns relax the spring decreasing outlet pressure.



Lifting and Handling

Wooden cases should be lifted using either a Fork Lift Vehicle or a Crane with adequate Safety Approved slings applied to carry the weight, which will be evenly distributed within the case.

Important: All manual handling operations should be carried out in compliance with the Manual Handling Operations Regulations 1992 (SI 1992/2793) (EC Directive 90/269/EEC).



Storage

If valve is bound to be stored longer than 6 months, turn back adjusting screw to remove compression from spring. (Re-adjust spring compression on installation).

Valves with Screwed ends shall have plugs fitted in their connections to prevent ingress of dirt etc. Flanged valves shall have their bores blanked off.

We recommend that plugs/blanks be removed immediately prior to installation.



Installation and Commissioning

It is most important that the pipeline be clean and free from dirt, scale, etc.

Fit valve in pipeline with flow as indicated by arrow cast on valve body and with adjusting screw in vertical position above or below pipeline.

It is also advisable to fit a stop valve on high-pressure side of line.



Maintenance

Examine annually for signs of defect, damage or deterioration.

Give special attention to contact/seating faces, if damaged these should be re-faced. Discs, diaphragms, seals and springs should be replaced if there is any sign of deterioration.

All parts should move freely in their respective guides.

Note: Quote the unique valve serial number when ordering spare parts.



Safety Warning!

Before dismantling ensure that the valve has been isolated from the pressure and the adjusting screw has been removed.



Dismantling and Reassembly

Dismantling:

To remove Disc: When the pressure is off: Remove; Adjusting Screw (1) and Locknut (2); Setscrews (23) and Bonnet (5); Ball (3) ensuring it is not misplaced; Spring Carrier (4) and Spring (6); Joint (8). Next remove Cap (22) and Joint (20): Secure Spindle (10) and remove Locknuts (19) and Disc Holder (18): Disc (17) can now be removed from Disc Holder (18).

To remove Seals: After removing Disc Holder (18), Spindle (10) can be removed through top of Body (15). Seal (11) on Spindle (10) can now be removed. Next turn Seal Housing (12) anticlockwise to remove from Body (15). Remove Joint (14). Seal (13) can be extracted from Seal Housing (12).

Note: Replace all joints with new ones.

Reassembly:

To replace Seals: Carefully replace both Seals ensuring they are fitted correctly with the V shape towards the pressure as shown in the illustration.

To replace Disc: Replace Spindle (10) in Body (15); clean Disc Holder (18) and push in replacement Disc (17) ensuring it sits squarely in Disc Holder, no bonding is necessary. Slip assembled Disc and Disc Holder over Spindle and secure with Locknuts (19).

Fit new Joint (20) and replace Bottom Cap (22). Replace Spring (6); Spring Carrier (4) and Ball (3); fit new Joint (8) and secure Bonnet (5). Replace Adjusting Screw (1) together with Locknut (2). Readjust the set pressure, as necessary, by means of the Adjusting Screw. Locknut (2) should then be tightened.

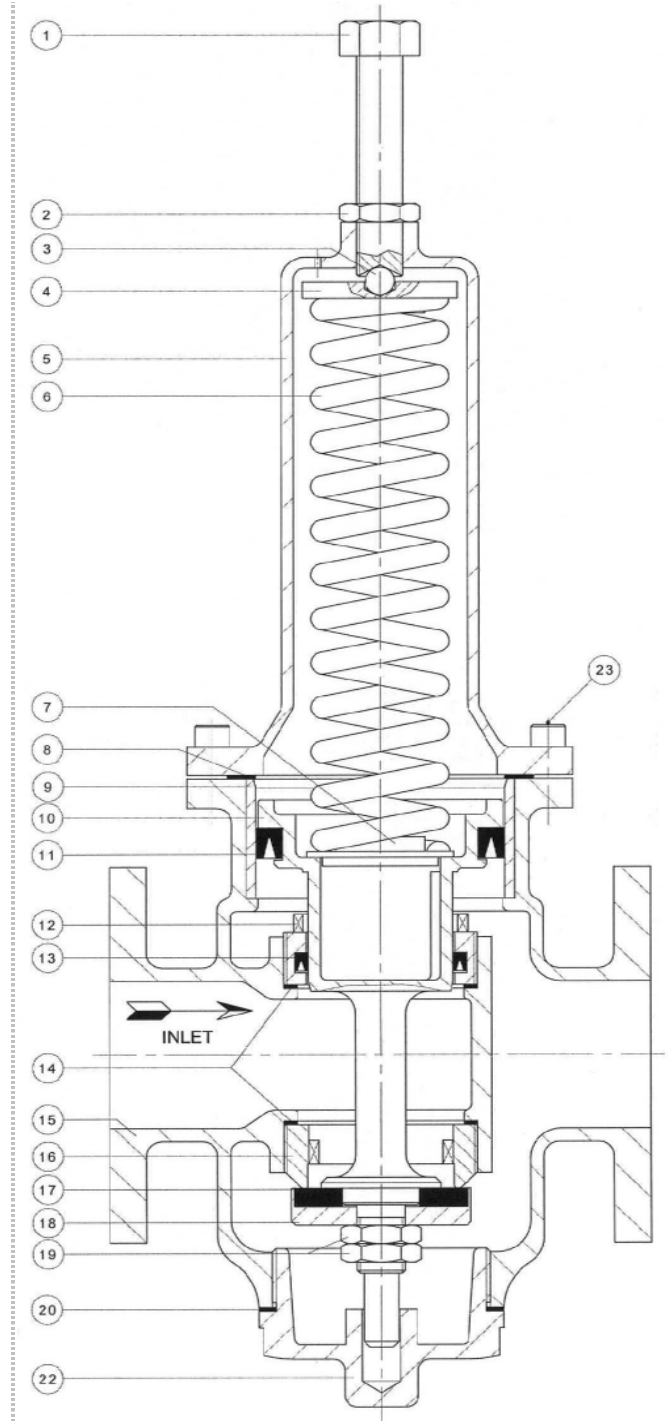

Item	Description	Qty
1	Adjusting Screw	1
2	Locknut (Adjusting Screw)	1
3	Ball	1
4	Spring Carrier	1
5	Bonnet	1
6	Spring	1
7	Spring Locator	1
✱ 8	Joint (Bonnet)	1
9	Liner	1
10	Spindle	1
✱ 11	Seal, Large	1
12	Seal Housing	1
✱ 13	Seal, Small	1
✱ 14	Joint (Seal Housing & Seat)	2
15	Body	1
16	Seat	1
✱ 17	Disc	1
18	Disc Holder	1
19	Locknut	2
✱ 20	Joint (Cap)	1
22	Cap	1
23	Socket Head Setscrew	Various

✱ Recommended spare parts

EC DECLARATION OF CONFORMITY

Issued in accordance with the

PRESSURE EQUIPMENT DIRECTIVE (PED) 97/23/EC

We hereby declare that, in compliance with the above Directive, the product(s) detailed below, have been manufactured in accordance with conformity assessment module D1 'Full quality assurance (ISO 9001)' as approved by Lloyds Register (Notified Body No. 0038), of Middlemarch Office Village, Siskin Drive, Coventry, CV3 4FJ, UK, under EC Certificate of Conformity RPS 0160389/02.

Product Description – Pressure Accessory

Product Reference – Type D Reducing Valve

Comprising – Not Applicable

Serial Number – Not Applicable

Applicable Standards – None

Other Applicable Directives – None

Signed: *A. Derrick*
Name: A. J. Derrick
Position: Managing Director
Date: 24th April 2002

