

# OPERATING INSTRUCTIONS

Category IV Safety Accessory

Type 3500 Relief Valve



Notified Body No. 0038



## Application

Suitable for compressed air, gas, water, oil and steam service.



## Operation

The set pressure can be varied as required by compressing or relaxing the spring using the adjusting screw:

Clockwise turns compress the spring increasing the set pressure.

Anti-clockwise turns relax the spring decreasing the set pressure.

## Lifting and Handling

Wooden cases should be lifted using either a Fork Lift Vehicle or a Crane with adequate Safety Approved slings applied to carry the weight, which will be evenly distributed within the case.

**Important:** All manual handling operations should be carried out in compliance with the Manual Handling Operations Regulations 1992 (SI 1992/2793) (EC Directive 90/269/EEC).



## Storage

Valves with Screwed ends shall have plugs fitted in their connections to prevent ingress of dirt etc. Flanged valves shall have their bores blanked off.

We recommend that plugs/blanks be removed immediately prior to installation.



## Safety Warning!

Discharge from outlet may be violent and must not be allowed to create a hazard to persons or property.



## Testing

It is recommended that the following tests be carried out before installation of the valve: Seat tightness and set pressure.

## Test Equipment

Connect valve inlet to a pressure vessel, of at least 100 litres capacity, in which pressure may be raised gradually and measured by means of a precision pressure gauge.

## Seat Tightness Test

The valve outlet should be fitted with an appropriately sized leakage detector (see Fig. 1) in accordance with API 527.

Raise inlet pressure to 90% of set pressure and check that the number of air bubbles per minute which pass through the water does not exceed the values below:

Orifice	Maximum Leakage (Bubbles per minute)
From D to F	40
From G to T	20

Should the leakage exceed the stated value, refer to table "Faults in Operation" (Fig. 2)

EQUIPMENT FOR SEAT TIGHTNESS TEST

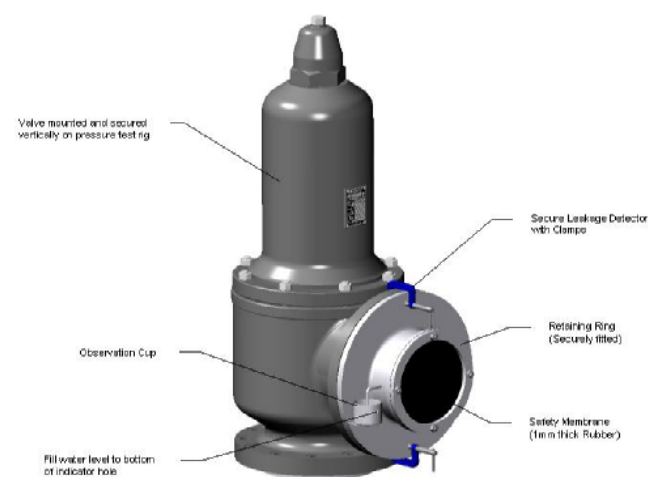

Fig. 1 - API 527 compliant leakage detector

## Set Pressure Test

Check that valve starts opening at required set pressure (refer to Valve Nameplate for correct value), tolerating a change of +/- 0.15kg/cm<sup>2</sup> for set pressures of less than 5kg/cm<sup>2</sup> and of +/- 3% for set pressures of 5kg/cm<sup>2</sup> and higher.

**Do not pop the valve if a tank of adequate capacity is not available, to avoid denting the seat, which would cause leakage.**

Changes outside the stated tolerances must be corrected by varying the spring compression using the Adjusting Screw (13).

To regulate the set pressure:

1. Fit valve to Test Rig with no pressure on valve inlet.
2. Remove the cap (3).
3. Prevent Disc Holder (7) rotating by holding Spindle (5) with screwdriver in slot on Spindle end.
4. Loosen Locknut (14) (fitted to Adjusting Screw (13))
5. Adjust using Adjusting Screw (13) until the desired set pressure is achieved. Do not allow Disc Holder (7) to rotate.
6. Reassemble Cap (3).

**Note:** For each set pressure check; Locknut (14) must be tightened.

## Opening Pressure Adjustment Settings

The following table gives an approximate guide to the amount of adjustment needed to vary the opening pressure. Variations in springs are not taken into account.

Orifice	D	E	F	G	H	J	K	L	M	N	P	Q	R	T
Percentage variation of opening pressure relative to 1mm of adjusting screw stroke	33	22	18	15	12	9	7.5	5.5	4.5	4	3.5	2.5	2.2	1.8

## Cold Setting of high temperature valves

Cold setting of high temperature valves is often necessary. In this case valves must be set at a pressure above the set pressure according to the percentages shown in the following table:

Working temperature °C	Percentage increase over set pressure
from -265 to +100	-
from 101 to 230	2%
from 231 to 480	3%
from 481 to 540	4%

This percentage increase offsets relaxation of the spring, caused by expansion of the body and bonnet.

## Cold Setting of valves for steam service

When possible, valves for steam service should be tested with steam.

When these valves are set with air at ambient temperatures, the following percentage increases in set pressure must be borne in mind:

Set pressure Kg/cm <sup>2</sup>	Percentage increase over set pressure
from 0.5 to 7	2%
from 7.1 to 21	3%
from 21.1 to 70	4%
from 70.1 to 210	5%

## Setting valves with constant back pressure

When there is a constant back pressure, valves without a balancing seal are set differentially.

**Example:** A valve, without a balancing seal, has a set pressure of 20 kg/cm<sup>2</sup> and a constant back pressure of 3 kg/cm<sup>2</sup>: Set valve at 20 - 3 = 17kg/cm<sup>2</sup>. This value is then increased by the corresponding percentage required for the relative high temperature.

Valves fitted with a balancing seal are only subject to variation due to high temperature or steam service.



## Safety Warning!

Consult Broady Technical Staff before making any changes to process conditions.

## Blowdown

Broady Safety Relief Valves are fitted with a single blowdown ring which may be used to regulate the blowdown.

**Note:** Blowdown tests must be carried out with the use of a compressed air plant of high capacity especially for large sized valves.

To correct the blowdown setting proceed as follows:

- i) Loosen Clampscrew (4) to allow rotation of Blowdown ring; if the ring is not accessible through the valve outlet, remove Clampscrew completely and rotate the ring with a screwdriver inserted into the hole left by the screw.
- ii) Rotate blowdown ring (33) upwards to increase/downwards to decrease blowdown.

When the desired blowdown is reached, tighten the Clampscrew (4).

The blowdown test, carried out with low discharge capacities, gives a reseating pressure higher than that, which would occur in discharge conditions. Therefore, to obtain the same reseating conditions as for a valve during operation, lower the blowdown ring by two notches.

**In no case must the blowdown ring be fitted in contact with the disc holder. The blowdown ring must be rotated at least two notches to lower it away from the disc holder.**



## Installation Handling

When moving the valve, for installation/maintenance purposes, it is recommended that an appropriate M10/M20 Lifting Eyebolt (65)<sup>f</sup>, fitted in place of Plug/Gag (36), be used. Utilising this Eyebolt a Safety Approved chain/strap, of adequate strength, may then be used, in conjunction with a suitable crane, to lift and move the valve. <sup>f</sup> Lifting Eyebolt (65) Not supplied.



## Installation and Commissioning

It is most important that the pipeline and valve connections be clean and free from dirt, scale, etc.

Avoid bumping or shaking valve, to prevent misalignment of trim and damage to flange faces.

Fit valve in pipeline with flow direction as indicated by arrow cast on valve body; with inlet down and Adjusting Screw in vertical position above pipeline.

It is also advisable to fit a stop valve on high-pressure side of line.

Use inlet and outlet pipework as short as possible and of dimensions equal to the valve connections.

Uniformly tighten fasteners securing valve connections to pipework.

Secure outlet pipework in order to reduce vibration and avoid strain on outlet flange.

Avoid elbows with small curvature radii on the outlet pipe: for high temperature gas and vapour discharge, use expansion joints.

After valve has been installed make it pop at least twice to allow automatic alignment of trim.



## Maintenance

### Regular Checks:

Check at regular intervals, for signs of obvious faults.

Leakages must be repaired immediately, especially when the medium is poisonous, highly volatile or very explosive.

When valve is fitted with lifting device, vent periodically (at least three or four times a year) to check operation. During these tests the pressure must be at least 75% of the full working pressure.

### Annual Checks:

Examine annually for signs of defect, damage or deterioration.

Give special attention to contact/seating faces, if damaged these must be re-machined and lapped in.

Springs should be replaced if there is any sign of deterioration.

All parts should move freely in their respective guides.

**Note:** Quote the unique valve serial number when ordering spare parts.

### Lapping the Disc

Use a cast iron or plate glass block of suitable size, with a perfectly smooth and flat surface. Apply a small quantity of lapping compound to smooth surface of block. Pass Disc (4), across smooth surface, in a figure of eight movement. Lift Disc periodically away from block so that lapping compound may flow from edges towards centre.

### Lapping the Nozzle Seat

Use a cast iron or plate glass block of suitable size; check that it does not tilt, to avoid rounding off edges. Apply lapping compound to smooth surface of block. Pass Nozzle (2) seating surface across smooth surface in a figure of eight movement. During lapping operation, make sure no foreign matter is on either lapped surface or block.

**Note:** Lapped parts must be carefully cleaned before assembling, to remove every trace of lapping compound.



## Safety Warning!

Before dismantling ensure that the valve has been isolated from the pressure and the adjusting screw has been removed.



## Dismantling and Reassembly

### Dismantling:

1. Remove Cap & Joint (3 & 32).
2. Measure position of the Adjusting screw (13) and record for re-assembly purposes.
3. Unscrew Locknut (14) and remove with Adjusting screw (13).
4. Remove Bonnet (10) from Body (1) by unscrewing Nuts (24).
5. Remove Spring Carriers (17) and Spring (29) from Spindle (5).
6. Using Spindle (5) as a handle, lift out remaining internals.
7. Remove Pin (9) and unscrew Stem (11) from Disc Holder (6).
8. Remove Stem (11) from Guide (25).
9. Remove Disc (4) from Disc Holder (6) by tapping Disc Holder firmly onto a clean wooden surface, care should be taken not to misplace the Circlip (35).
10. Unscrew Clampscrew (16) from Body (1).
11. Unscrew Blowdown Ring (8) from Nozzle (2).
12. Unscrew Nozzle (2) from Body (1).

**Note:** Replace all Joints with new ones.



## Danger of Explosion!

Oxygen Service - Carefully degrease all components before assembling valves. Failure to do so will result in an explosion.

**OPERATING INSTRUCTIONS**

**Danger of Explosion!**  
 Oxygen Service - Carefully degrease all components before assembling valves. Failure to do so will result in an explosion.

**Reassembly:**

Carry out reverse of operations listed for disassembly, taking care to:  
 Avoid scratching lapped surfaces. Note: To prevent damage to Disc/Nozzle faces hold Spindle (5) with screwdriver in slot on Spindle end; turn whilst compressing Spring.

Clean the trim thoroughly throughout. Lubricate Adjusting Screw, Spring Carrier and all threads with graphite grease.

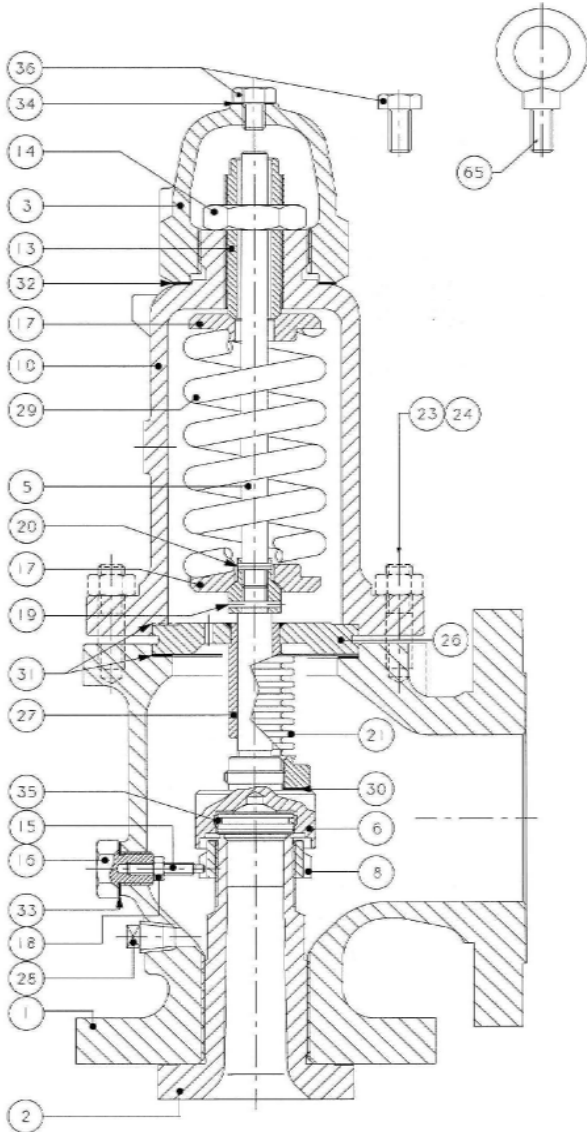

Item	Description	Qty
1	Body	1
2	Nozzle	1
3	Cap	1
4	Disc	1
5	Spindle	1
6	Disc Holder	1
8	Blowdown Ring	1
9	Pin (Disc Holder)	1
10	Bonnet	1
11	Stem	1
12	Collar	1
13	Adjusting Screw	1
14	Locknut (Adjusting Screw)	1
15	Screwed Pin	1
16	Clampscrew	1
17	Spring Carrier	2
18	Locknut (Screwed Pin)	1
19	Pin (Collar - Large)	1
20	Pin (Collar - Small)	1
21	Bellows	1
22	Washer (when Bellows not fitted)	1
23	Stud (Body/Bonnet)	Various
24	Nut (Body/Bonnet)	Various
25	Guide Assembly	1
28	Drain Plug	1
29	Spring	1
30	Joint (Bellows)	1
* 31	Joint (Guide)	1/2*
* 32	Joint (Cap)	1
* 33	Joint (Clampscrew)	1
* 34	Joint (Plug/Gag)	1
35	Circlip (Disc)	1
36	Plug/Gag	1
65	Lifting Eyebolt	1

\* Valves not fitted with Bellows have two Guide Joints.

\* Recommended spare parts

<sup>†</sup> Lifting Eyebolt (65) Not supplied.

**Fig. 2 - Faults in Operation**

FAULT	CAUSES	SOLUTIONS
Leakage	(1) Presence of foreign matter between seat and disc  (2) Scratching or pitting on seat surface  (3) Valve used with a medium other than specified when ordering  (4) Valve not mounted vertically.	(1) Discharge valve once or twice consecutively. Should leakage continue, disassemble valve and clean trim.  (2) Disassemble valve, grind and lap seat.  (3) Lap seat and disc more finely if the valve originally ordered for liquid service, is used with gas  (4) Correct the installation.
Discharge at incorrect pressure	(1) Variable back pressure  (2) Back pressures different from specified when ordered  (3) Loosening of lock nut on spring adjusting screw.  (4) Poor trim alignment.	(1) Check that discharge takes place in piping whose dimensions are equal to or greater than those of the outlet connections of the valve, and that the discharge piping is free from obstruction.  (2) The valve must be re-calibrated correcting the spring compression for the revised set pressure.  (3) Tighten lock nut after re-calibrating the valve.  (4) Discharge the valve 2 or 3 times to allow self-alignment of the trim.
Chatter (rapid opening and closing cycle)	(1) Blowdown ring incorrectly adjusted.  (2) Insufficient discharge capacity.	(1) Ensure that the blowdown ring is in the lowest position for liquid service. For valves used on gas; regulate suitably.  (2) Check that the discharge piping is not too long. Check that the valve is not undersized.



**Broady Flow Control Limited,**  
 English Street,  
 Kingston upon Hull,  
 East Yorkshire,  
 HU3 2DU.  
 www.broady.co.uk  
 Telephone: 01482 619600  
 Facsimile: 01482 619700

**EC DECLARATION OF CONFORMITY**

Issued in accordance with the

**PRESSURE EQUIPMENT DIRECTIVE (PED) 97/23/EC**

We hereby declare that, in compliance with the above Directive, the product(s) detailed below, have been manufactured in accordance with conformity assessment modules **B + D** 'Type examination' and 'Full quality assurance (ISO 9001) for production, final inspection and test' as approved by Lloyds Register (Notified Body No. 0038), of Middlemarch Office Village, Siskin Drive, Coventry, CV3 4FJ, UK, under EC Type Examination Certificate RPS 0160353/04 and EC Certificate of Conformity RPS 0160389/01.

**Product Description** – Safety Accessory

**Product Reference** – Type 3500 Relief Valve

**Comprising** – Not Applicable

**Serial Number** – Not Applicable

**Applicable Standards** – None

**Other Applicable Directives** – None

Signed: A. Derrick  
 Name: A. J. Derrick  
 Position: Managing Director  
 Date: 24<sup>th</sup> April 2002



Declaration of Conformity

Form QF 186/B+D iss. A