



BROADLY

F L O W C O N T R O L

TYPE 9 PRESSURE SUSTAINING/SURPLUS VALVE

The **Type 9 pressure sustaining/surplus valves** are designed to sustain and control the upstream pressure and pass surplus mediums into a zone where they can perform useful work or be recovered and conserved. The type 9 has a piston and lid of equal diameter, making the two areas balanced. This makes the valve suitable for applications where variable back pressures are present.

Valves are supplied in sizes ½" to 6" and can be manufactured in Gunmetal, Cast Steel and Stainless Steel with ends screwed female BSP or flanged ends to customers requirements.

The standard set pressure range of the Type 9 is 0.70 to 9.00 Bar g, although higher and lower set pressures can be accommodated. **(Consult Broadly Technical Sales Engineers for further information).**

Specification

All valves are supplied with a nitrile diaphragm for air, gases, oils, etc. as standard, but other materials are available on request. Valves for steam service are supplied with a metallic diaphragm.

Description of Action

Pressure is admitted at the inlet and acts upon the area of the lid. To regulate the valve the spring is compressed an amount equal to the load acting against it, thus keeping the valve lid on its seat. As the pressure tends to increase above this setting, the extra load acting on the lid compresses the spring further and this allows it to leave its seat and excess pressure discharges to atmosphere or pump

suction. Similarly when the pressure is decreased the spring overcomes the lighter load imposed on the lid and thus the valve closes.

Compressing the spring **increases** the set pressure, **relaxing** the spring **decreases** the set pressure.

Installation

Surplus valves are not usually fitted in the main pipeline as in the case of reducing valves. They should be fitted in a branch line from the main, in a horizontal position with the spring uppermost and the flow indicated by the arrow cast on the body. It is most important that the pipe is clean and free from dirt, scale etc.

Instructions for fitting a new diaphragm

Replacing an elastomer Diaphragm : When the valve is isolated from the pressure slacken off the spring. Remove the dome, spring, locknut, nut and piston. It will probably be found that the diaphragm will come away freely. After removal of the diaphragm the spigot on the body should be cleaned. Grind in the valve faces if necessary, and after replacing the valve see that the distance piece and the face of the body are level. Fit the new diaphragm, making sure that it is a good fit on the spindle. Care should be taken when tightening the fasteners in order to prevent damage to the diaphragm. Re-adjust the pressure as necessary by means of the adjusting screw.

Typical Carbon Steel Type 9

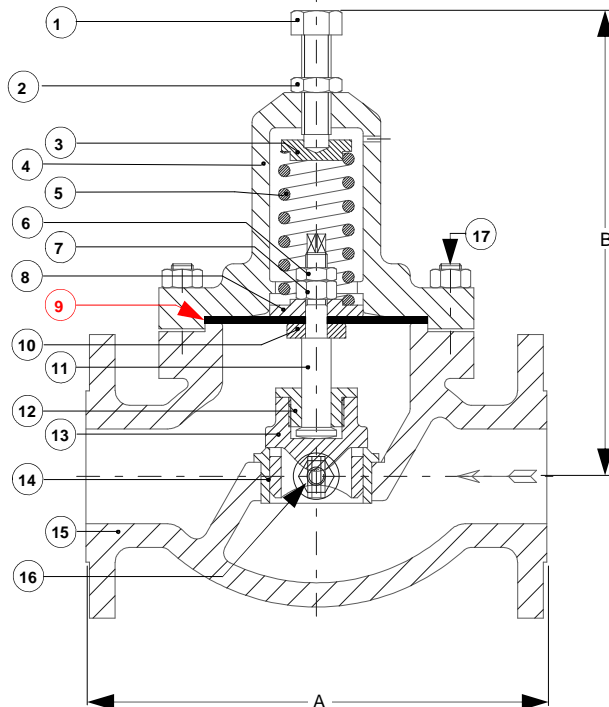

Item	Description	Material
1	Adjusting Screw	Stainless Steel
2	Locknut	Stainless Steel
3	Spring Carrier	Carbon Steel
4	Dome	Carbon Steel
5	Spring	Carbon Steel
6	Locknut	Stainless Steel
7	Nut	Stainless Steel
8	Piston	Carbon Steel
9	Diaphragm	Nitrile
10	Distance Piece	Stainless Steel
11	Spindle	Stainless Steel
12	Valve Lid Cap	Stainless Steel
13	Lid	Stainless Steel
14	Seat	Stainless Steel
15	Body	Stainless Steel
16	Seat Securing Screw	Stainless Steel
17	Setscrews	Stainless Steel

This Item is a recommended spare.

TYPE 9 PRESSURE SUSTAINING/SURPLUS VALVE

Typical Installation

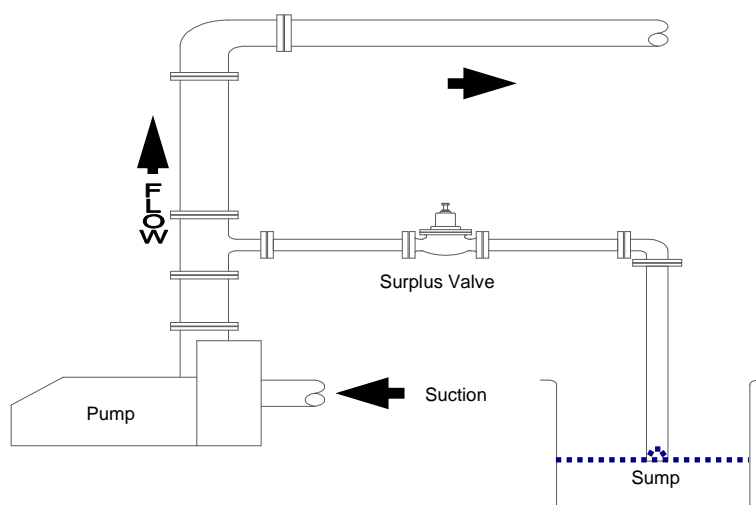

Saturated Steam Capacities in kg/hr

Set Pressure (Bar g)	Valve Size										
	15	20	25	32	40	50	65	80	100	125	150
0.70	11	24	45	68	99	177	276	399	712	1112	1611
2.00	19	45	79	124	179	299	499	717	1271	2020	2905
3.50	29	64	115	181	258	463	726	1044	1847	2905	4776
4.80	38	84	150	236	340	594	953	1339	2406	3813	5448
6.90	50	113	204	317	463	808	1275	1838	3268	5130	7354
8.30	55	133	238	376	540	953	1498	2156	3859	5992	8716

Air Capacities in Nm³/hr

Set Pressure (Bar g)	Valve Size										
	15	20	25	32	40	50	65	80	100	125	150
0.70	13	28	52	83	120	203	339	475	849	1335	1924
2.00	22	54	95	149	215	361	600	861	1539	2400	3442
3.50	33	76	137	217	312	531	864	1245	2218	3464	5005
4.80	45	101	181	282	407	689	1133	1631	2898	4529	6522
6.90	61	135	249	385	543	939	1539	2208	3917	6114	8833
8.30	73	161	287	453	647	1121	1779	2582	4597	7202	10372

Water Capacities in l/min

Set Pressure (Bar g)	Valve Size										
	15	20	25	32	40	50	65	80	100	125	150
0.70	5	12	21	34	47	86	131	195	340	531	763
2.00	9	20	36	57	86	145	231	331	590	927	1336
3.50	12	27	47	73	109	190	300	431	768	1200	1727
4.80	14	32	57	87	127	227	354	509	909	1418	2045
6.90	17	38	68	106	154	272	422	613	1086	1671	2432
8.30	19	42	73	118	168	295	463	668	1186	1854	2673

Disclaimer

The information, specifications and technical data contained in this catalogue are subject to change without notice. The user should verify all technical data and specifications prior to use. Broady Valves does not warrant that the material and information contained herein is current or correct and assumes no responsibility for the use or misuse of any such material and information by the user.

BROADY FLOW CONTROL LIMITED

English Street, Kingston-Upon-Hull,
East Yorkshire, HU3 2DU.

Telephone: 01482 619601 Fax: 01482 619701

Email: sales@broady.co.uk Website: www.broady.co.uk